

PROFESSIONAL SERIES

MODEL 850

PLATINUM

EDGE  
MAT CUTTER

**INSTRUCTION AND OPERATION MANUAL**

Professional mat cutting system with aluminum baseboard, magnetic production stop, 32" (81cm) removable squaring arm, plus dual straight and bevel cutting heads



For best results use only authentic Logan blade #267



www.logangraphic.com  
**Logan Graphic Products, Inc.**  
1100 Brown Street  
Wauconda, IL 60084 USA  
Phone (847) 526-5515  
Fax (847) 526-5155  
Email - cs@logangraphic.com

Purchase Date

ID Number (on bottom of board)

Date (on bottom of board)

L3097N 4/10

# INTRODUCTION

The Logan 850 Platinum Edge Mat Cutter is designed specifically with the framer in mind. All the materials are heavy-duty to withstand the rigors of professional mat cutting and to provide the accuracy framers demand.

Features include super-smooth cutting head glides, 4- and 8-ply cutting capability, quick-change magnetic blade cartridges, micro-adjustable moving magnetic stop, 32" (81cm) removable scaled squaring arm, and heavy-duty all-metal construction with aluminum base. Use Logan Replacement Blade Model 267.

We are confident that the quality, accuracy and dependability of the Platinum Edge will be everything you expect in a professional mat cutter.

This instructional manual is written to acquaint you thoroughly with this product. Referred to at the outset, it will answer many questions that may arise during use. You will find that the time taken will be well worth it and you will be cutting top quality mats in no time.

## TABLE OF CONTENTS

Out Of Box Set Up .....	1
Changing/Installing Mat Cutter Blades.....	2
Cutting A Beveled Mat.....	3
Line to Line Method .....	3
Production Stops Method.....	4
Platinum Edge Precision Mat Cutter Diagram .....	6
Sizing The Mat Board.....	7
Cutting V-Grooves.....	8
Making Adjustments .....	8
Re-squaring the Squaring Arm .....	8
Cutting Head .....	9
Bevel Blade Tip Adjustment Screw .....	10
Production Stop Micro-Adjustments.....	10
Mat Guide .....	10
Troubleshooting.....	11
More Great Logan Products.....	12
Warranty.....	13

# Out Of Box Set Up

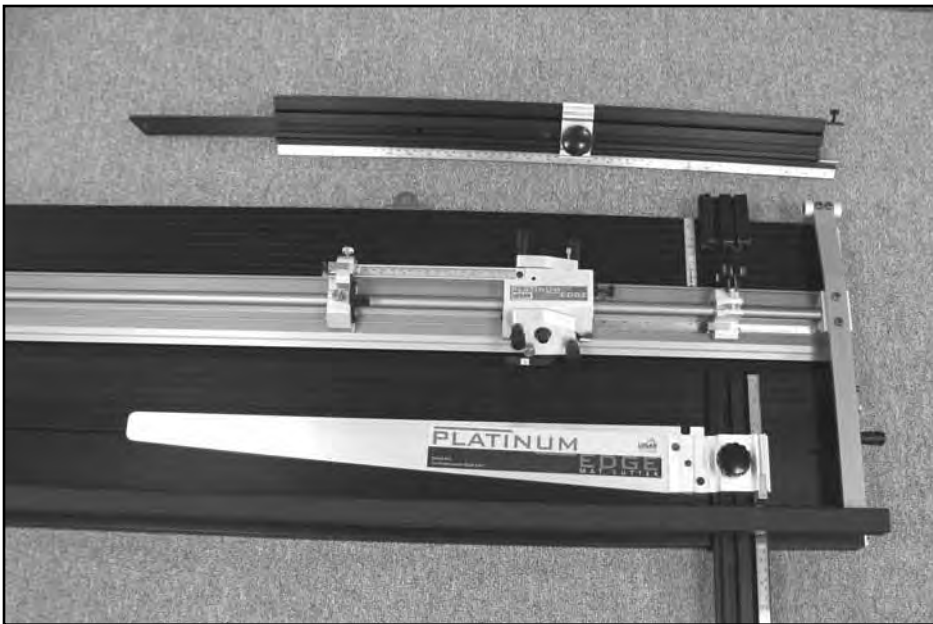

Figure 1



Above: Additional parts included in this package: Four Allen wrenches, sizes 1/8", 5/32", 5/64" & 1/16", Handle Bar Lift Knob and screw, two replacement blade packs (5 ct. each)

The Platinum Edge Mat Cutter has been aligned and calibrated at our facility before shipping. With a few simple steps, you will be able to set up your mat cutter and begin production immediately.

Remove the Platinum Edge Mat Cutter from the box and unwrap the pieces carefully. Your Platinum Edge should be set up on a flat, stable work table, aligned so that you can easily access the handle bar lift and cutting head (Figure 2.1). Follow the assembly guide (Figure 2.2).

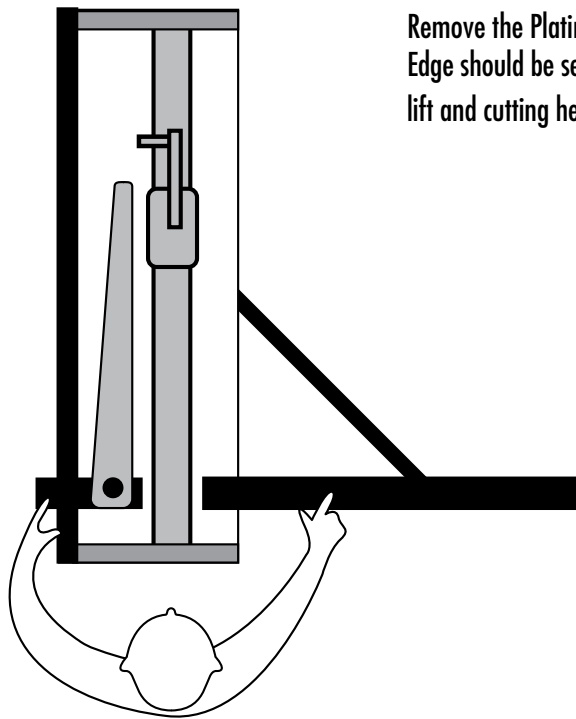

Figure 2.1

## ASSEMBLY INSTRUCTIONS

(See page 6 for parts identification)

1. Insert Right Side Squaring Arm into Squaring Arm Mount
2. Hook the Squaring Arm Strut onto the Strut Bracket
3. Attach the Handle Bar Lift Knob using the enclosed screw and 5/32" Allan wrench

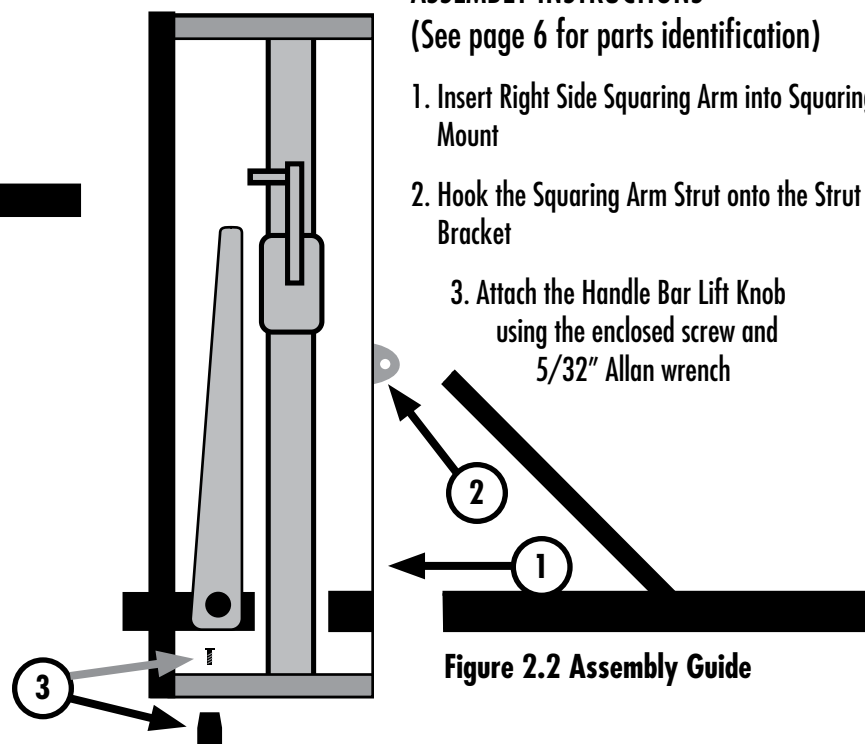
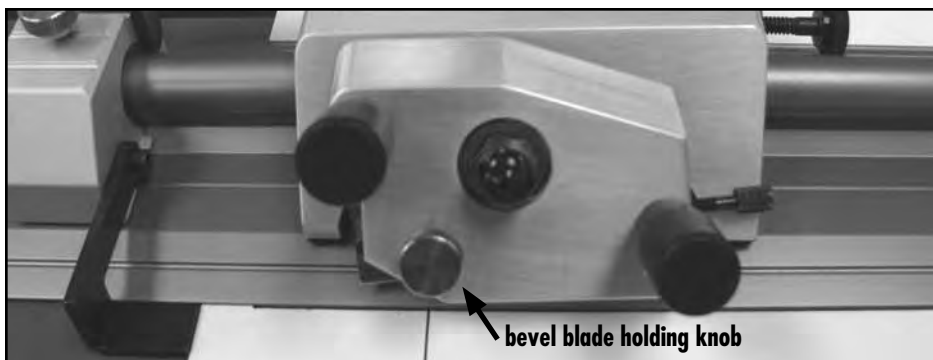
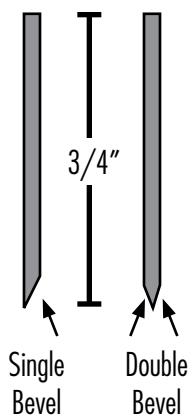

Figure 2.2 Assembly Guide

**IMPORTANT:** Do not oil or lubricate the cutting head or guide rail.

# Changing and Installing Mat Cutter Blades



**Figure 3**

**A note about Mat Cutter Blades: They are sharp. Super sharp. Imagine a sharp thing and then multiply it by a power of three. That sharp. So, be careful.**

The Platinum Edge Mat Cutter uses Logan Blade Model 267, which is a 0.012" thick double bevel blade. However, any blade that is 3/4" in height may be used, as long as the blade depth and production stops are adjusted accordingly for accurate results (See "Making Adjustments" starting on Page 16). Whether you use single bevel blades or double bevel blades is really up to you, but either version can be purchased from an authorized art materials dealer.

Always use a sharp blade when cutting mats. Signs your blade may be too dull include ragged cuts or a tendency for the blade to tear the mat rather than slice it. When a blade becomes dull you will need to remove it and either exchange it for a new one or, in the case of double bevel blades, reverse the blade to use the as-yet-unused side. To remove a blade magazine from the blade carrier, first loosen the bevel blade holding knob located beneath the front handle of the blade carrier (Figure 3).

Take hold of the black adjustment screw at the rear of the magazine and pull the magazine out. If the magazine does not come out smoothly, loosen the thumb screw a bit more.

## Setting the Bevel Blade Depth

Place a fresh blade on the magazine with the sharp edge down – the magnet will hold it in place (Figure 4). Insert the magazine into the blade holder slot until the rear of the magazine is flush with the rear of the blade holder, then tighten the blade holding knob securely. You will be able to feel where the blade holding knob falls into the divot machined into the blade magazine (Figure 5).

Blade depth adjustments are made by loosening the blade holding knob slightly and turning the blade depth adjustment screw in or out. **Each blade should be set so it only just cuts through the mat being cut and slightly scores the slipsheet.**

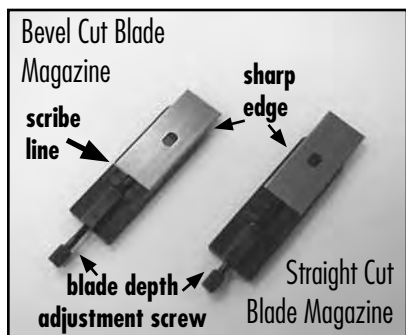

**Figure 4**

NOTE: It is important to distinguish the difference between the Bevel Cut and Straight Cut blade magazines. Identify the scribe line on the Bevel Cut Blade Magazine. This inserts on the left side (bevel side) of the cutting head.

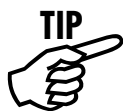

The bevel cut blade magazine features a scribe line (Figure 4) as a suggested place to align the rear of the blade. This line was factory tested with a commonly available 4-ply mat board. Your matboard thickness may vary, in which case the blade will require adjustment as described above.



**Figure 5**

# Cutting a Beveled Mat

## Line to Line Method

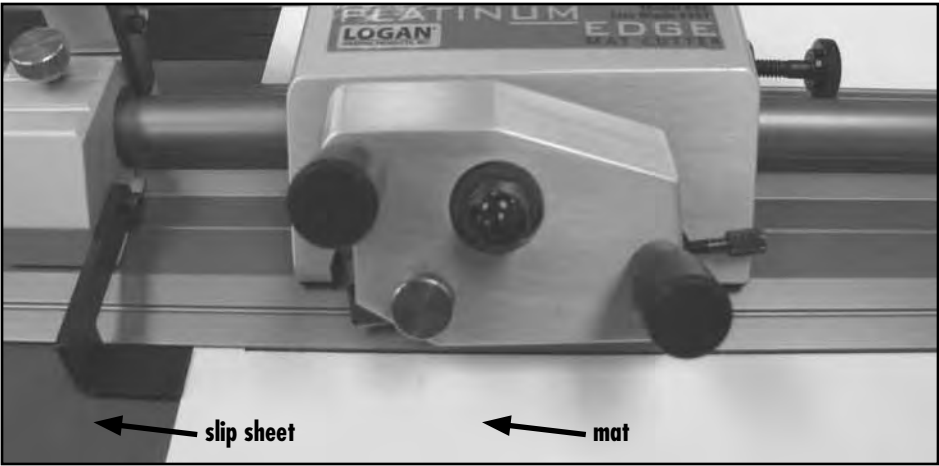

Figure 6

Bevel cutting is done from the back side of the mat with the colored side down. Always use a slip sheet of scrap mat board beneath the mat you intend to cut in order to provide a crisp edge (Figure 6).

A slip sheet usually measures about 6 inches wide and is at least a few inches longer than the mat you intend to cut. The bevel blade should extend far enough so that it slices through the mat you are cutting and then just score into the slip sheet.



**TIP** After you have cut a few mats, you may wish to move the slip sheet or flip it so that the blade does not follow the same slip sheet furrows. Having fresh mat board beneath the surface you intend to cut helps to provide a crisply cut edge.

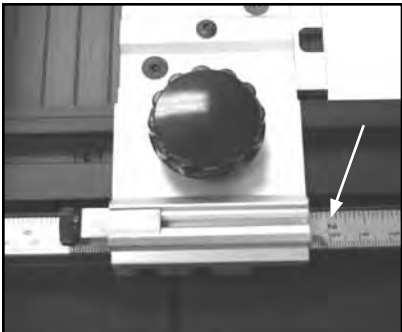

Figure 7

### Line to Line Method

*Step 1*

Set the mat guide only at desired border size like 2" for this example (Figure 7).

*Step 2*

Insert a mat board blank, color side down, on top of a slip sheet. Using a pencil, mark lines along the left side of the cutting bar from end to end of the mat board blank and repeat for all four sides.

*Step 3*

Slide the cutting head to the top line and position it so the entry point of the blade tip is roughly 3/16" above the pencil line (Figure 8). Rotate the blade holder to insert the blade, and pull back to cut while applying steady, even pressure, stopping when the tip of the blade passes the bottom pencil line by roughly 3/16".



**A suggestion to learn where to start and stop with your blade:**

Mark out four even size borders on a mat blank. Then set your production stops (see page 7) to cut that same size even border. Cut the mat using the production stops. While cutting, watch and take mental note of where the blade enters and exits the mat in relation to the pencil lines while using the production stops. Seeing where the blade starts and stops using the production stops will teach you where to manually duplicate these entry and exit points when cutting line to line.

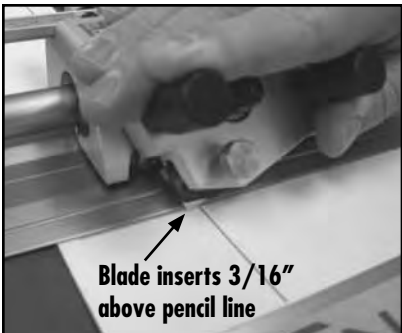

Figure 8

*Step 4*

Repeat this process for the next side, and stop to inspect the corner. If the corner is hung up and the window is not dropping out, OR if there is significant overcut in the corners, then adjust where you start and stop.



**TIP** The mat cutting technique described above (without production stops or stop/start indicators) is used by professional framers. Although it takes some practice to perfect, the tips provided here combined with patience and persistence will help you quickly master the technique.

continued on page 4

## Cutting a Beveled Mat

### Line to Line Method (continued)



1. While rotating the blade into the mat, hold the cutting head still to prevent it from creeping forward upon insertion, which can cause an overcut.
2. Maintain constant downward pressure on the bevel blade holder throughout the cut to ensure the blades passes through the mat board.
3. Pushing down on the long handle bar during cutting is unnecessary and not recommended.
4. **Cutting 8-ply or Double Thick Mat Board** - After increasing the blade depth, use a piece of test 8 ply mat board to mark out and line to line cut one corner that can be inspected. Do not use the production stops for this test cut. Cut from line to line, starting and stopping the blade approximately 3/8" past the marked lines. Inspect the slip sheet to see you are just barely scoring into the surface. Inspect the corner on the test mat to check for overcuts.
5. Cleaning debris from under the cutting bar - Occasionally some debris may collect under the cutting bar, which could cause cutting inconsistencies. To remove the debris, use a clean cloth, soft brush or compressed air. Do not use cleaning fluids that may leave a film on the mat cutter. This film may damage the matboard.

## Cutting a Beveled Mat

### Production Stops Method

Using the ruler guides on the left side squaring arm (Figure 9), cutting head (Figure 10), and clamp rail (Figure 11), set the desired border width for your finished mat. The example shown is for cutting a mat with a 2" border.

Standing at the end of the mat cutter, use the handle bar lift to raise the guide rail above the surface of the base (Figure 12).

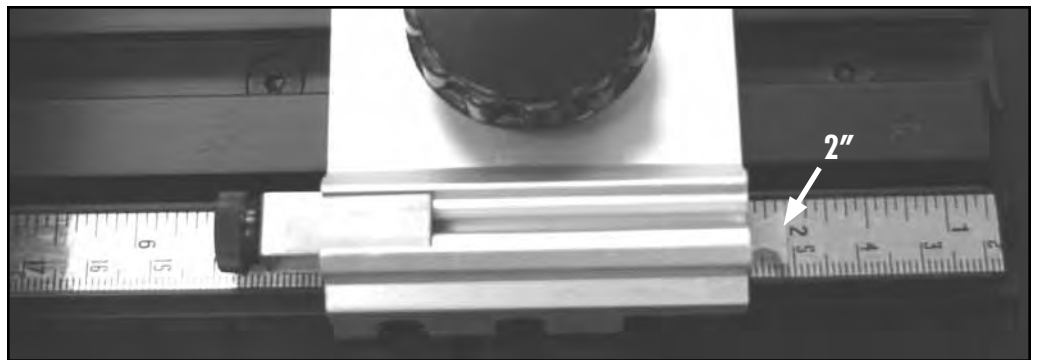

Figure 9

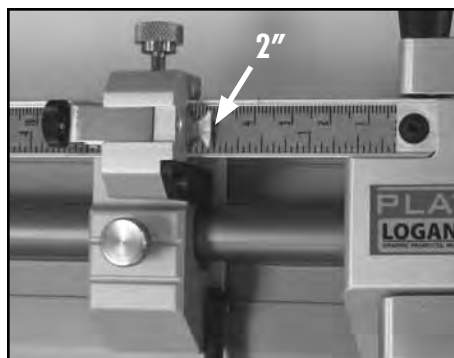

Figure 10

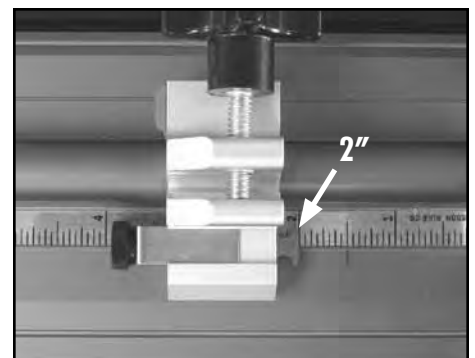

Figure 11

## Cutting a Beveled Mat *Production Stops Method* (continued)



Figure 12

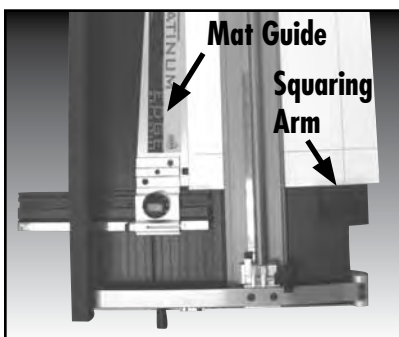

Figure 13

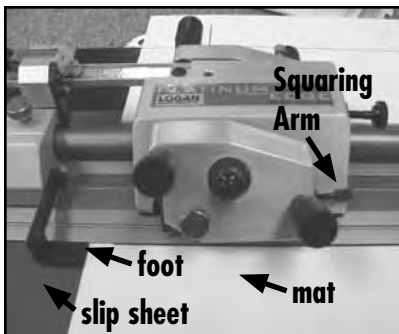
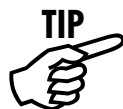

Figure 14



Slide the mat and slip sheet beneath the guide rail and align the lower corner of the mat you intend to cut at the junction of the squaring arm and mat guide. It is important to make sure the mat you are about to cut sits squarely against the squaring arm and the mat guide. Lower the lifter bar mechanism to secure the mat in place for cutting (Figure 13).

Slide the cutting head up the guide rail until the magnetic moveable stop catches the cutting head. The black foot of the stop should be in an elevated position to avoid catching on the slip sheet.

Slide the cutting head down the guide rail until the black foot of the automatic stop has gone past the upper edge of the slip sheet and then drop it down into position. When the foot catches the edge of the mat you are about to cut, rotate the cutting head down into the mat, starting your cut (Figure 14).

Pull the cutting head towards you, and the magnetic moveable stop will automatically release. Continue the cut with a steady pull until the cutting head makes contact with the lower stop. Rotate the blade out of the mat. Raise the handle bar using the handle bar life (Figure 12) to release the mat, turn the mat 90 degrees, align the corner of the mat back into the corner of the mat stop and mat guide and repeat the cutting process.

1. While rotating the blade in, hold the cutting head still to prevent it from creeping forward upon insertion which can cause an overcut.
2. Maintain constant forward pressure on the bevel blade holder throughout the cut to ensure the blades passes through the mat board.
3. Pushing down on the long handle bar during cutting is unnecessary and not recommended, as it may cause hooks and curves in the mat opening.

# Platinum Edge Precision Mat Cutter

## Diagram

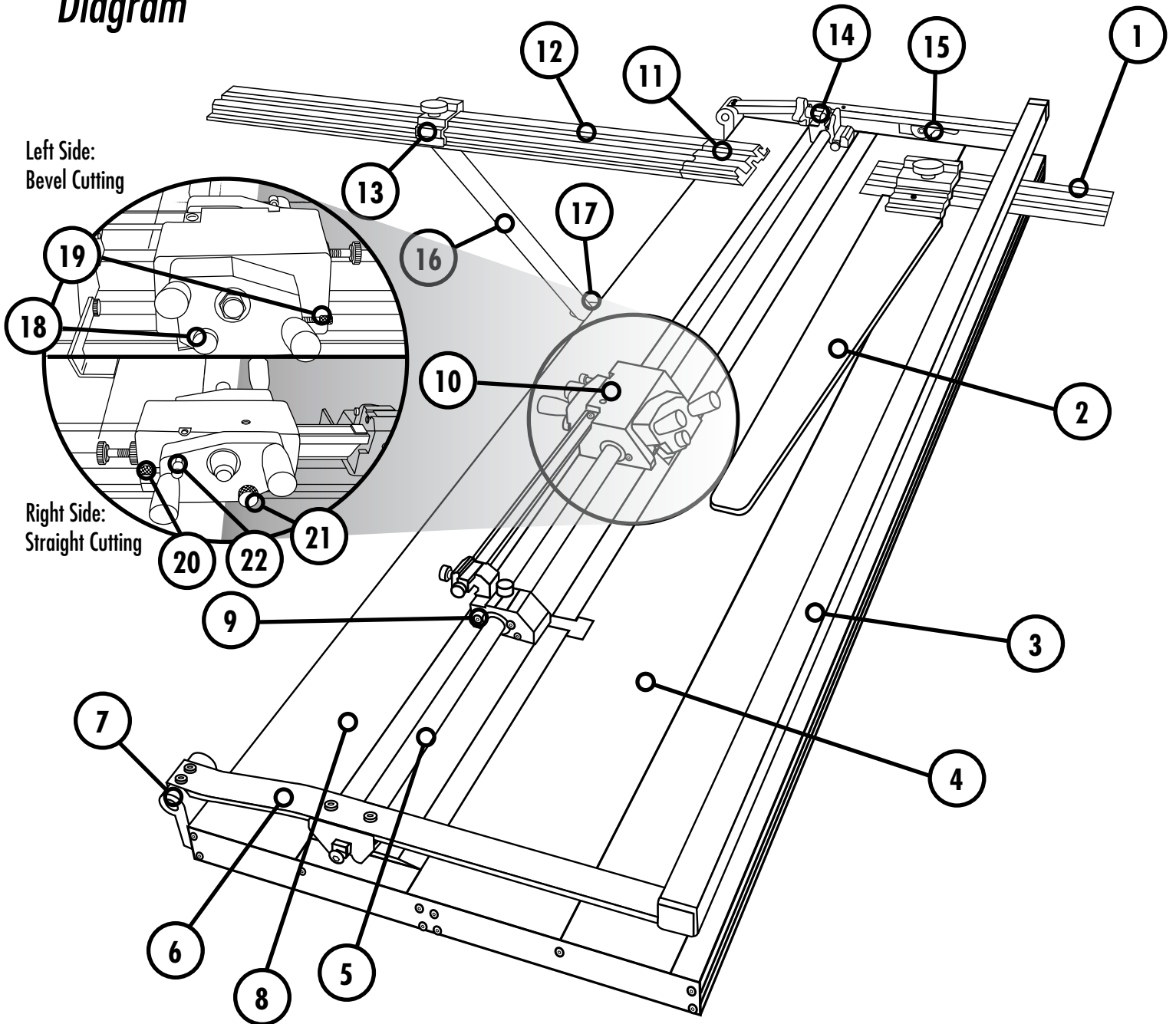

- 1 Left Side Squaring Arm
- 2 Mat Guide
- 3 Handle Bar
- 4 Base
- 5 Cutting Bar
- 6 Support Arm
- 7 Hinge
- 8 Cutting Bar Bracket

- 9 Magnetic Moveable Stop
- 10 Cutting Head
- 11 Squaring Arm Mount
- 12 Right Side Squaring Arm
- 13 Squaring Arm Stop
- 14 Bottom Stop
- 15 Handle Bar Lift
- 16 Squaring Arm Strut

- 17 Strut Bracket
- 18 Bevel Blade Holding Knob
- 19 Bevel Blade Holding Magazine
- 20 Straight Blade Holding Magazine
- 21 Straight Blade Holding Knob
- 22 Lockdown Pin



# Sizing Mat Board

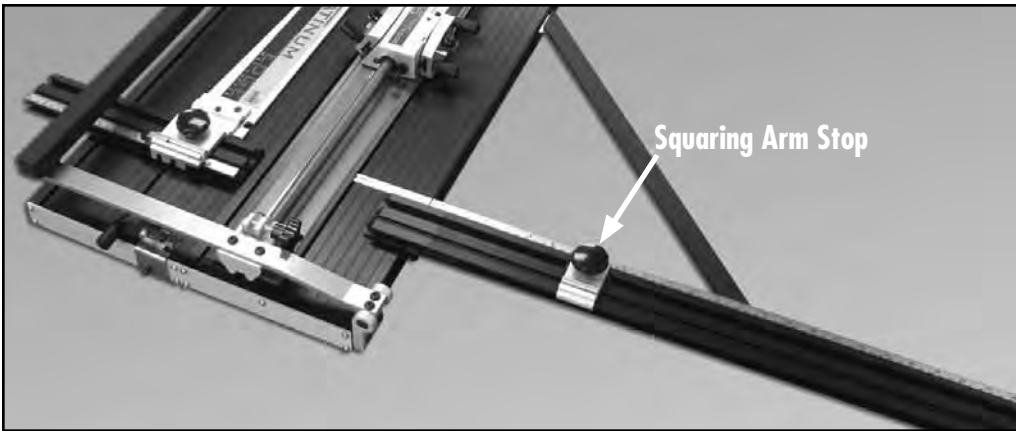

Figure 15

Full size mat boards can be cut down to a desired size using the straight blade side on the cutting head. The removable squaring arm is helpful for squaring and sizing the mat (Figure 15).

### Step 1

Set the squaring arm stop for the measurement you want and tighten the knob (Figure 15).

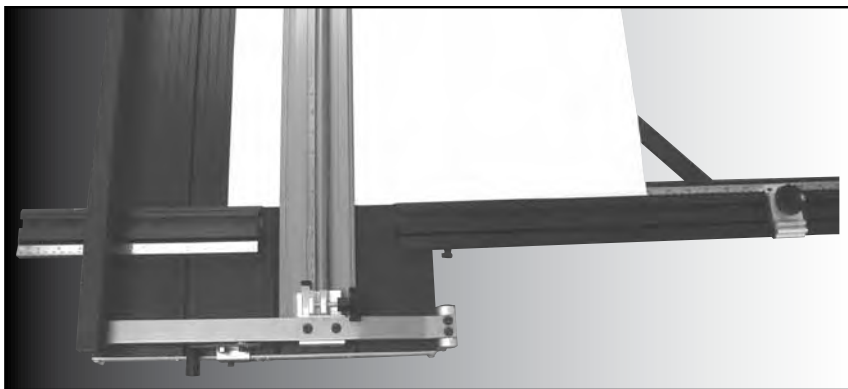

Figure 16

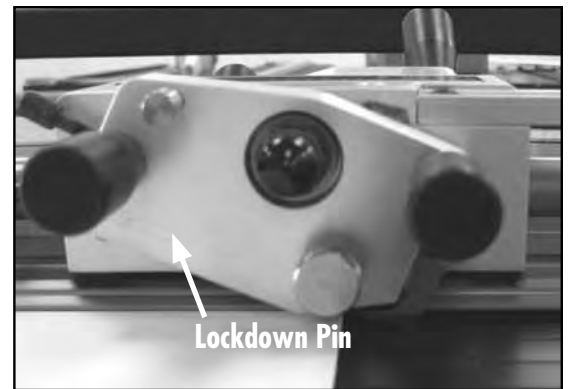

Figure 17

### Step 2

Remove the mat guide and the slip sheet. Place the mat board under the cutting bar and against the squaring arm and squaring arm stop (Figure 16). The lower stop should be moved all the way to the bottom of the guide rail bar – it does not need to be tightened.

### Step 3

Adjust the straight cutting head blade so it will cut about 1/32nd of an inch deeper than the mat board you are cutting. To cut, position the cutting head above the top edge of the mat board and rotate the straight cutting head down as far as it will go. Lock it in position with the lockdown pin for the cutting process (Figure 17).

### TIP

Full sheet mat board is most often not square when purchased new. Leaving any factory corners can produce unsquare mats. If you need to square the board, trim a small amount off all four sides of the mat board using the straight cut side. When trimming, cut opposite sides first and then the remaining opposite sides. (trim each long side first then trim the short sides)

## Cutting V-Grooves

For professional quality V-Grooves, the Logan Model 706 Universal V-Groover is compatible with Model 850. It is available from picture frame suppliers and art supply dealers. See Page 21 for more information.

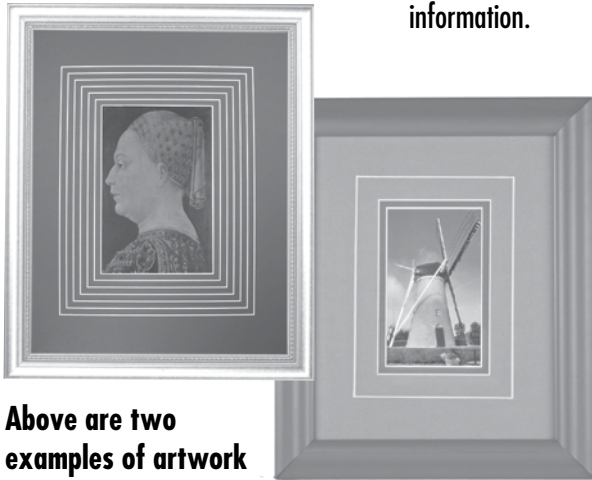

Above are two examples of artwork that are enhanced with V-Groove mats

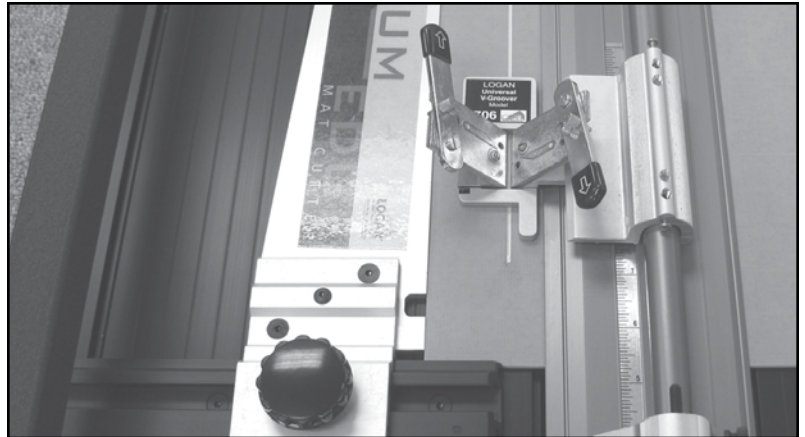

Figure 18

## Making Adjustments

From time to time, you may need to make adjustments to your Platinum Edge Mat Cutter. The following categories will guide you through the process of adjusting your mat cutter if some fine tuning is needed.

### Re-squaring the Squaring Arm

It is possible over time for the squaring arm to come slightly out of square to the cutting bar. In this situation, you will need to re-square the squaring arm.

Before making any adjustments, check the squareness of the machine with this test. You will need an L shaped carpenter's square found in any hardware store.

#### Step 1

Insure that you have the long 32" squaring arm tightly attached to the squaring arm mount.

#### Step 2

Remove any mat board or slip sheet material from the machine.

#### Step 3

Slide the cutting head to the far end of the cutting bar out of the way.

#### Step 4

Place the L shaped carpenter's square into the machine into the 90 degree corner formed by the cutting bar and the squaring arm. (Fig 19 & 20)

#### Step 5

Check the relationship of the L shaped carpenter's square to the cutting bar and squaring arm. It should fit tightly with no movement. If there is movement, determine which direction the squaring arm needs to move to be square again and allow the L shaped carpenter's square to snugly fit into the machine with no movement.

continued on page 9

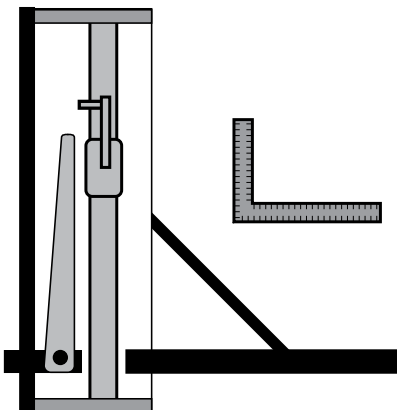

Figure 19

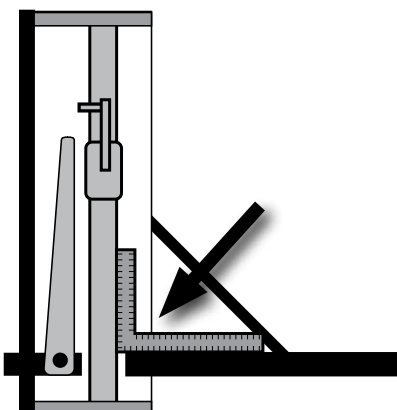

Figure 20

## Making Adjustments (continued)

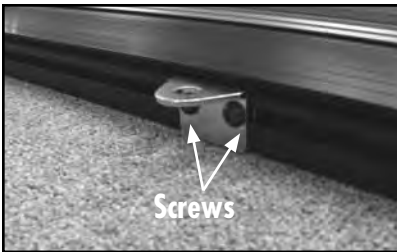

Figure 21 - Strut Bracket

### Step 6

Loosen the squaring arm strut bracket screws (Figure 21) and gently tap the bracket forward or backward to pull or push the squaring arm the direction it needs to go to be square again. Moving the strut bracket up or down slightly will push or pull the angle of the squaring arm back into square. (Fig 22).

### Step 7

Once the squaring arm is square to the L shaped carpenter's square, re-tighten the squaring arm bracket in place. The machine is now re-squared.

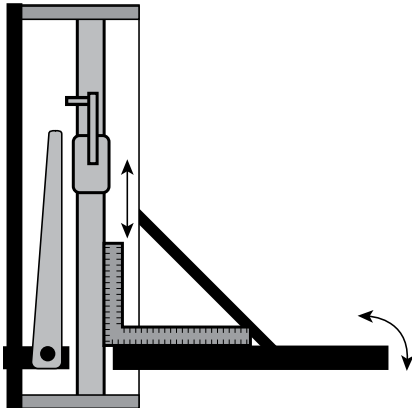

Figure 22

## Cutting Head

If the cutting head begins to wobble side-to-side, there are three setscrews to tighten.

**Caution: do not over-tighten these screws.**

On the right side of the cutting head there are two recessed holes. One is to the left of the 90 degree blade carrier behind the knurled screw and one is to the right of the blade carrier behind the extended blade (remove blade before adjusting) (Figure 23).

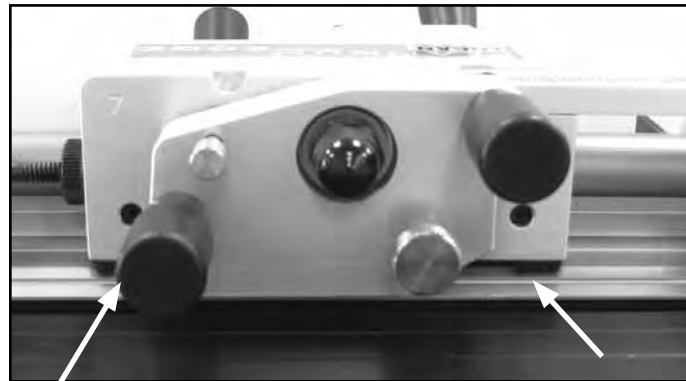

Figure 23

With the Allen wrench provided, slightly tighten the front bushing screw. After each adjustment, slide the cutter back and forth until some resistance is felt. If there is too much resistance, loosen the screw very slightly so the cutting head slides easily. Repeat this process on the rear bushing. The third adjustment screw for the cutting head is in a recessed hole on the top of the head (Figure 24).

This tightens the roller bearing. Again, slightly tighten the bearing screw and check for resistance by sliding the cutting head. As soon as resistance is felt, loosen the setscrew slightly.

**Caution: do not over-tighten these screws or damage to the bearing or bushings may result.**



Figure 24

## Making Adjustments

(continued)

### Blade Tip Adjustment Screw



Figure 25

### Bevel Blade Tip Adjustment Screw

If you are experiencing hooks or curves in your cuts even though the blade depth is set properly so it only scores into the backing sheet, an adjustment to the blade tip adjustment screw may be needed (Figure 25). Remove the bevel blade magazine and the blade and locate the small screw on the magazine located near where the tip of the blade rests. Using the Allen wrench provided, turn the screw in slightly to put more pressure on the blade tip while cutting. **DO NOT OVERTIGHTEN.** Too much pressure from this screw can drive the blade into the cutting bar. Too little pressure from this screw can create "slack" in the blade which can allow it to flex while cutting which can produce hooks or curves.

### Production Stop Micro Adjustments

If you are experiencing over cuts or under cuts using production stops even though the blade depth is set properly so it only scores into the backing sheet, adjustments to the production stops may be needed. On the mat guide, bottom stop and magnetic movable stop, you will find a small knob that moves the indicator plate over the scale. This indicator plate can be moved slightly to correct an over cut or under cut. For example, if you are experiencing an over cut at the start of a 2" border cut using the magnetic movable stop, turn the micro adjustment on the magnetic movable stop to slightly less than 2" and then loosen and adjust the entire magnetic movable stop back to the 2" mark. This will remove some or all of the over cut allowing you to still set the stop properly at the 2" mark each time. For under cuts, turn the micro adjustment on the magnetic movable stop to slightly more than 2" and then loosen and adjust the entire magnetic movable stop back to the 2" mark. This will remove some or all of the under cut allowing you to still set the stop properly at the 2" mark each time.

### Mat Guide

Fine tuning the width of the border is done on the mat guide. If you need to make the border width a bit narrower, turn the mat guide micro adjustment knob counter-clockwise. Conversely, turning the knob clockwise will widen the border width slightly (Figure 26).

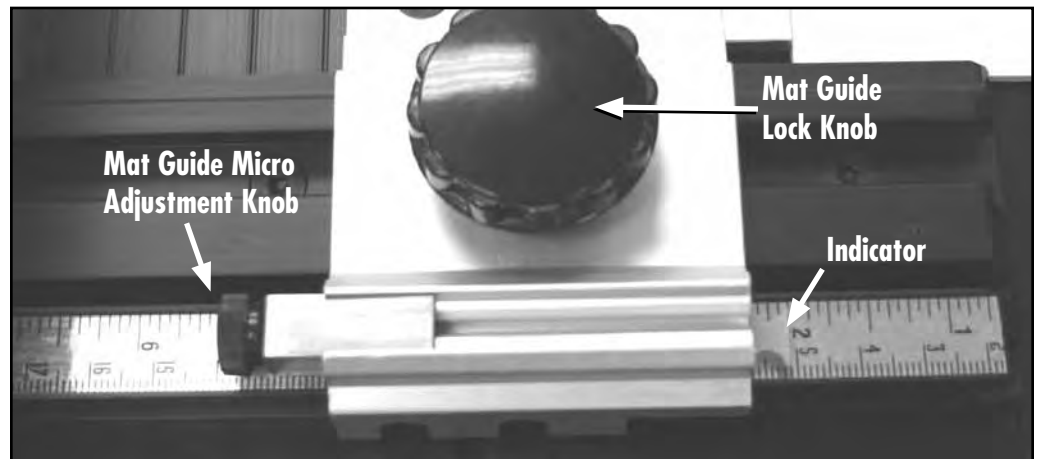

Figure 26

# Troubleshooting

Problem	Possible Reasons
Ragged cuts	<p>Cutting without a slip sheet (Page 3)</p> <p>Slip sheet is worn out (Page 3)</p> <p>Dull or chipped blade (Page 2)</p> <p>Inconsistent pressure being applied on the cutting head while cutting (Page 4)</p> <p>Putting unneeded pressure down onto the handle bar (Page 4)</p>
Overcut at the start of the cut	<p>Allowing the cutting head to “creep” forward upon blade insertion (Page 4)</p> <p>Starting the cut too far past the pencil line (Page 3)</p> <p>Too much blade depth (Page 2)</p> <p>Production stop not set properly or needs micro adjustment (Page 10)</p>
Overcut at the end of the cut	<p>Cutting too far past the bottom pencil line (Page 3)</p> <p>Too much blade depth (Page 2)</p> <p>Production stop not set properly or needs micro adjustment (Page 10)</p>
Blade not cutting through material	<p>Pushing down on the handle bar while cutting (Page 4)</p> <p>Inconsistent pressure being applied on the cutting head while cutting (Page 4)</p> <p>Debris caught under the cutting bar (Page 4)</p> <p>Blade depth set too shallow (Page 2)</p>
Cutting through the mat in some areas but not in others	<p>Pushing down on the handle bar while cutting (Page 4)</p> <p>Slip sheet not the full length of the mat being cut (Page 3)</p> <p>Inconsistent pressure being applied on the cutting head while cutting (Page 4)</p> <p>Debris caught under the cutting bar (Page 4)</p>
Hook in corner or long curve in the cut	<p>Too much blade depth allowing the blade tip to flex (Page 2)</p> <p>Dull blade (Page 2)</p> <p>Pushing down on the handle bar while cutting (Page 4)</p> <p>Slip sheet not the full length of the mat being cut (Page 3)</p> <p>Inconsistent pressure being applied on the cutting head while cutting (Page 4)</p> <p>Possible adjustment needed to the blade tip adjustment screw (Page 10)</p>
Cutting heads hard to pull when cutting	<p>Dull blade (Page 2)</p> <p>For bevel cutting, too much blade depth (Page 2)</p> <p>For straight cutting, did not remove slip sheet before cutting (Page 7)</p> <p>Possible adjustment needed on cutting head tension screws (Page 9)</p>
Borders of mats inconsistent size from one end to the other	<p>Not placing the mat and slip sheet tightly against the parallel mat guide (Page 5)</p> <p>Mat guide not parallel and needs adjustment (Pages 8-9)</p> <p>Mat board not squared properly before cutting (Page 7)</p>
Machine not producing square cuts when downsizing mat board	<p>Not placing the mat squarely against the squaring bar while cutting (Page 5)</p> <p>Squaring arm no longer square and needs adjustment (Pages 8-9)</p> <p>Trim all four sides of an unsquare mat board before using (Page 7)</p>
Cutting head loose on the rail	<p>Possible adjustment needed on cutting head tension screws (Page 9)</p>
Production stops producing over or under cuts	<p>Blade depth set too deep or too shallow (Page 2)</p> <p>Possible micro adjustment needed on the production stops (Page 10)</p>

# More Great Logan Products...

Logan does not sell directly. For information on where to buy Logan products, please visit [www.logangraphic.com](http://www.logangraphic.com), or call us at 800-331-6232.

## 850 Accessories

### Logan V-Groover - Model #706

Logan Surface V-Groover Offers a way to cut surface V-Grooves quickly and accurately with zero overcuts. Push-Pull action cuts V-Grooves right on the surface of the matboard eliminating any need for trimming or taping. Works entirely with stops.

**Replacement Blades - Model #1258**

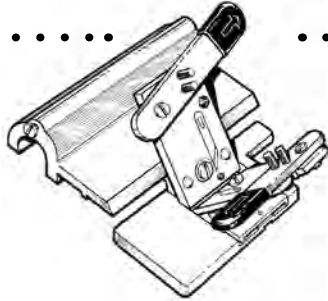

## Other Mat Cutting Accessories

### 3-Step Oval & Circle Mat Cutter - Model 201

3-Step Oval and Circle Mat Cutter is easy to use, fast and portable. Cuts ovals or circles on the surface of the matboard using a patented 3-step mechanism for gradual increase of blade depth.

Converts from oval to circle cutter with a turn of a knob. Ovals from 3 1/4" x 4 3/4" to 20" x 23". Circles from 4 1/2" to 20".

**Replacement blades - Model 324**

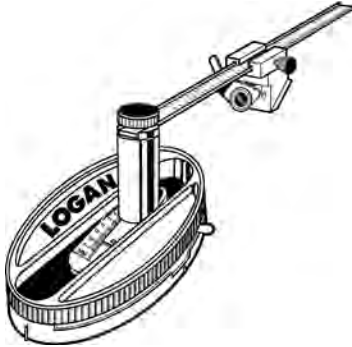

## Foamboard Cutting and Modeling Tools

### FoamWerks Tools and Accessories

Designed for model makers, artists, framers, architects, photographers, crafters and sign makers, FoamWerks tools cut foamboard easily and precisely. The complete family allows users to cut circles, straight lines, bevel edges, V-grooves, freestyle shapes and more.

**For product information, how-to videos, project ideas, where to buy and more, please visit: [www.foamwerks.com](http://www.foamwerks.com)**

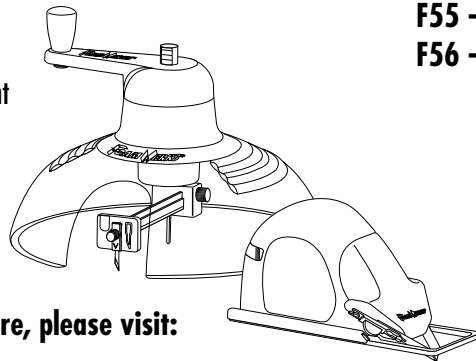

## Do-It-Yourself Framing Tools

### Precision Sander Model F200-2

Sands miters to perfect 45° angle for tight, square frames

- 10 lb wheel
- Adjusts 45° left, 90° and 45° right
- Micro adjustment for perfect 45°
- Aluminum oxide sand paper with life extending bar
- Sand up to 3 1/2" mouldings
- Dust removal bar

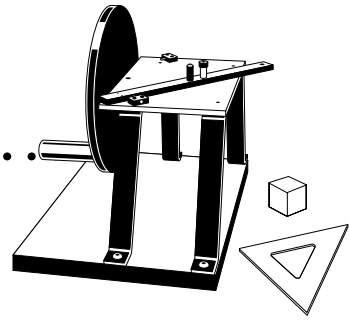

### Studio Joiner Model F300-1

Join frame corners simply and accurately

- Depth setting adjustment
- Drives all V-nail sizes
- Support spacer for irregular profiles
- For use with hard or soft woods
- Fits mouldings up to 2 1/2" (6.25cm)

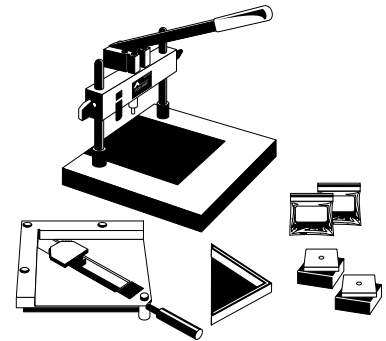

### Dual-Drive Point Driver - Model F500-1

Secure artwork, backing board and glass into hard or soft wood frames. Spring-loaded action drives both rigid and flexible points. For successful operation, use only authentic Logan points.

#### Replacement Points:

- F53 - Flex Point Strip 600 pcs.**
- F54 - Rigid Point Strip 600 pcs.**
- F55 - Flex Point Strip 2,500 pcs.**
- F56 - Rigid Point Strip 2,500 pcs.**



# WARRANTY

Logan Graphic Products, Inc. ("Logan") warrants the 850 Platinum Edge to be free from defects in parts and workmanship for a period of two years from the date of original purchase. Logan warrants that it will either repair or replace, at its sole discretion, any necessary replacement parts found to be defective. Should the product need to be returned to Logan for repair or replacement parts, authorization for any return must come from Logan in writing. Costs of returning the product to Logan, including insurances, shall be borne by the purchaser. Logan shall not be liable for any damages or losses, incidental or consequential, direct or indirect, arising from the use of this product. This warranty extends only to the original purchaser and is not assignable or transferable. This warranty is in lieu of all other warranties, expressed or implied.

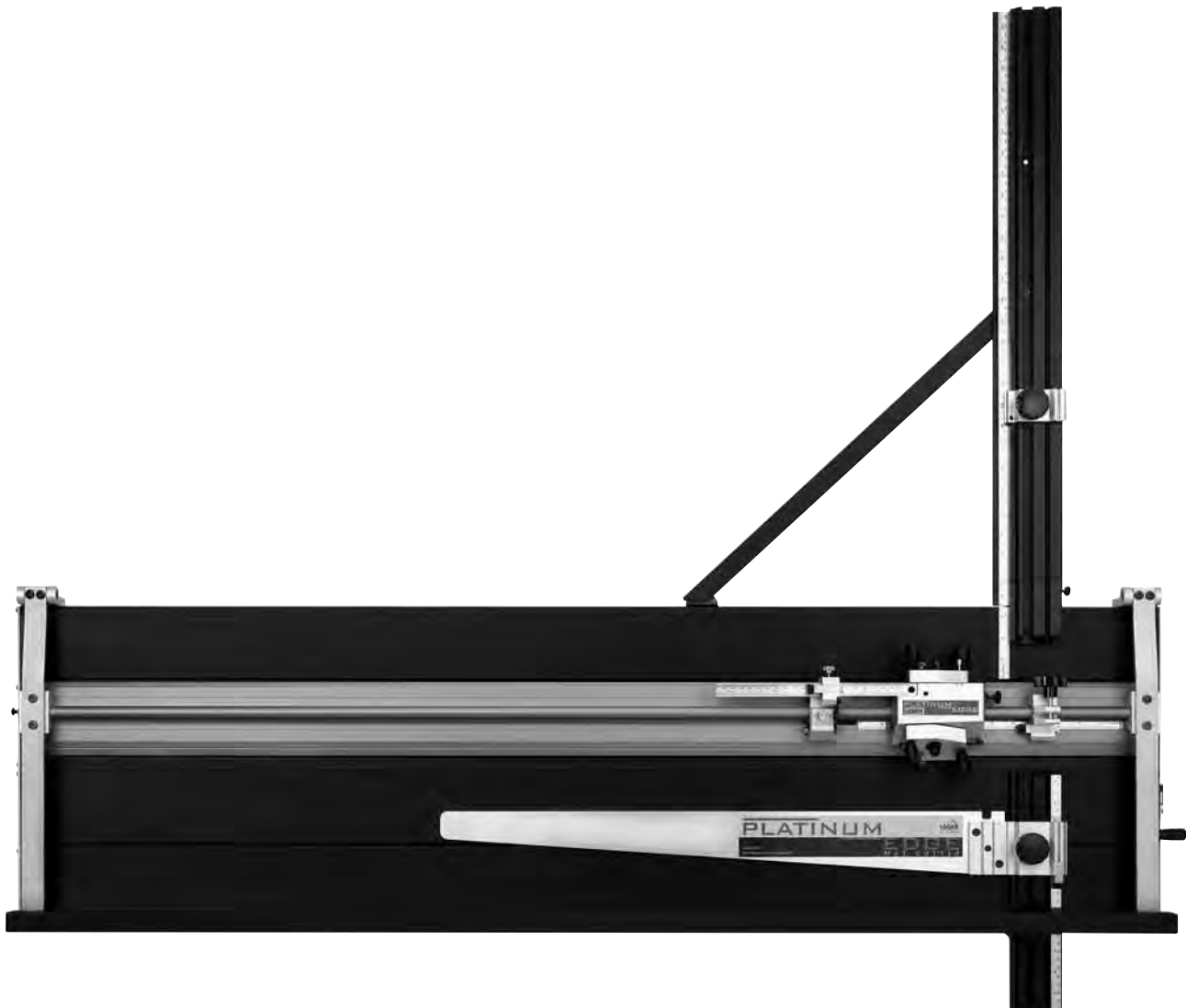

# Logan Quality Commitment

Logan Graphic Products, Inc. is committed to delivering products that work and exceed our customers' expectations. If you are dissatisfied with your tool's performance, do not understand the directions, or feel that you are not getting the results you expected, **DON'T GIVE UP!** Contact us by email or phone, and let us help solve your problem. We are here for you, and want you to be thrilled with your Logan purchase.

**email: [cs@logangraphic.com](mailto:cs@logangraphic.com)**  
**phone: 800 331 6232 • 847 526 5515**

